

P

The Brownstones at
PARK POTOMAC

The Sterling



The Sterling

A new Brownstone is the perfect fit for any personality. Throughout the four floors, sentimentalists will find room for a lifetime of personal treasures — and much more. The study provides a comfortable place for readers and thinkers. And the rooftop terrace will always save astronomers and dreamers a seat for stargazing. Of course, now you'll have time to enjoy these spaces, thanks to the Brownstone's low-maintenance lifestyle.

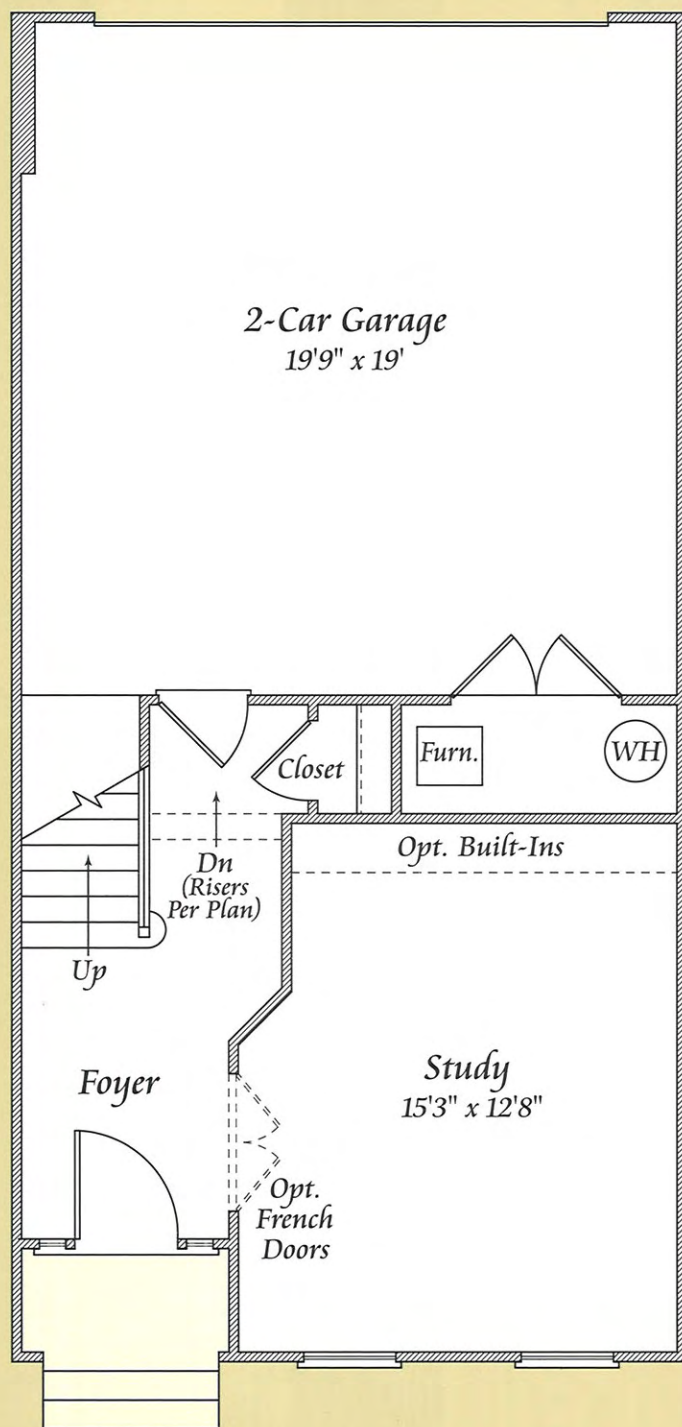

ENTRY LEVEL

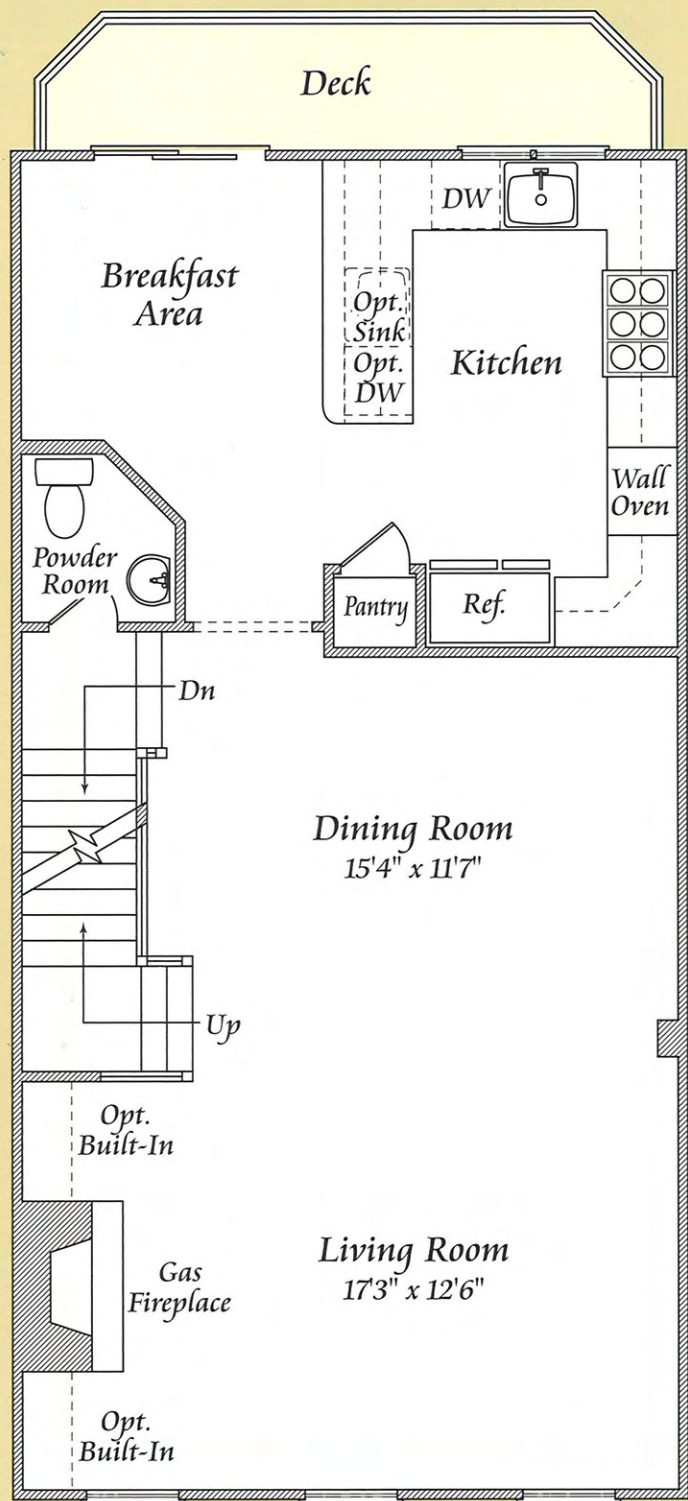

MAIN LEVEL
Optional Open Kitchen Plan Available

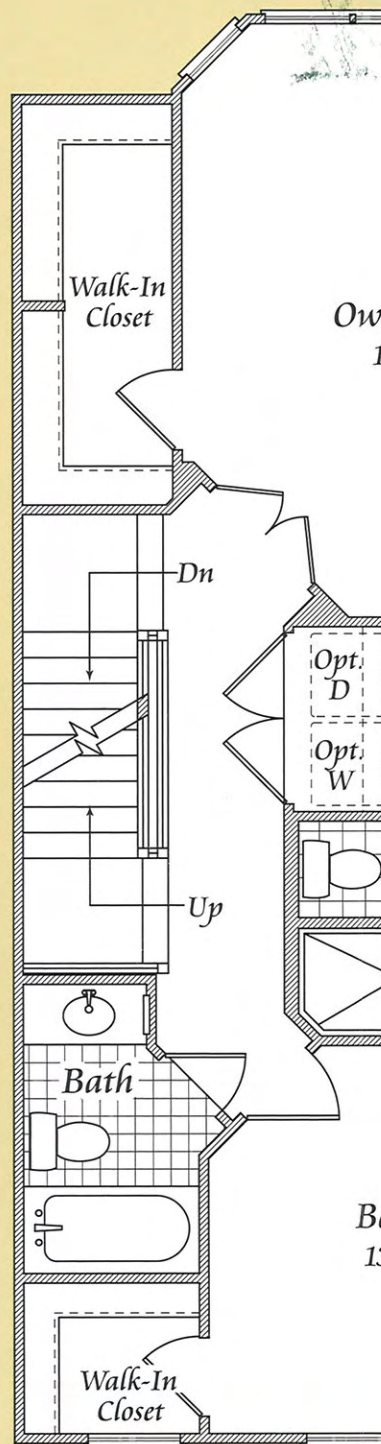

UPPER LEVEL
Owner's Suite Location



The Brownstones at
PARK POTOMAC

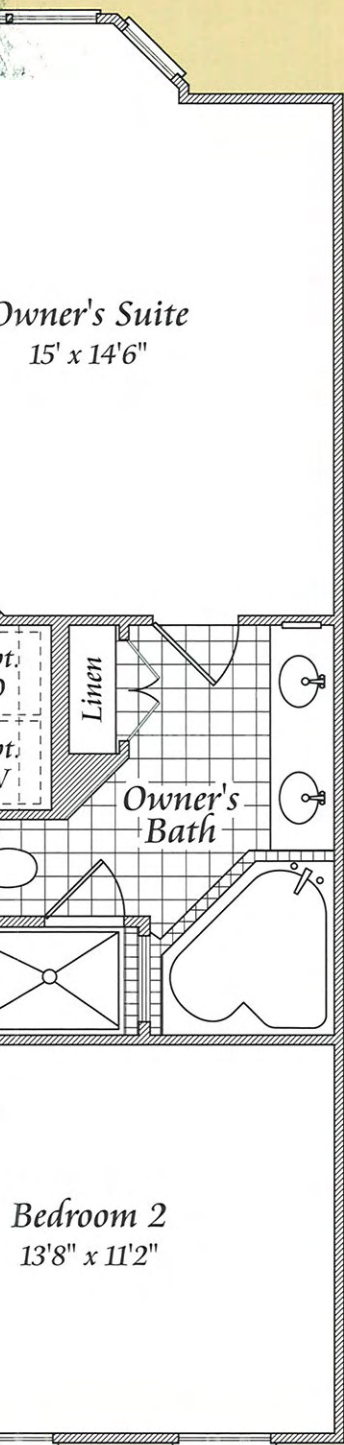

LEVEL
ation per Homesite

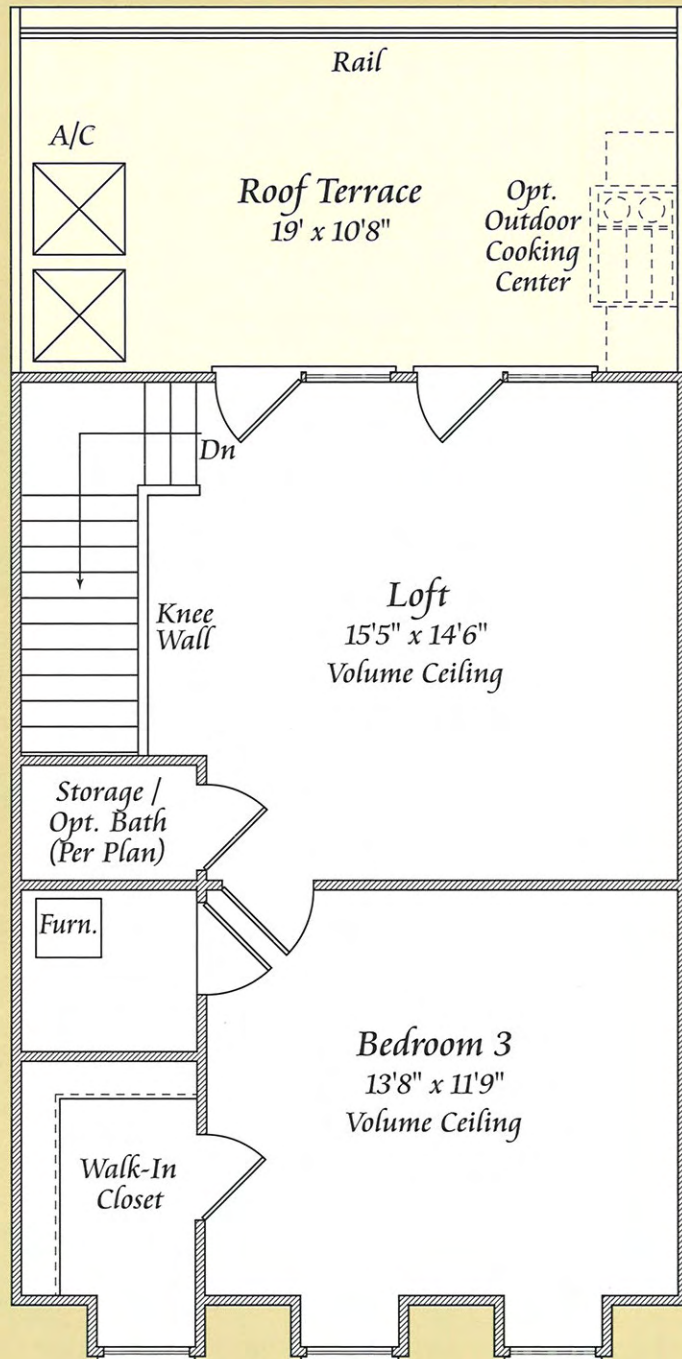

LOFT LEVEL

The Sterling

LUXURY APPOINTMENTS

EXTERIOR FEATURES

- Brownstone inspired exteriors with rich architectural details
- Oversized rooftop terrace
- Two-car garage with 2 remotes and wireless keypad
- Double-hung, double-pane, simulated divided light wood windows
- Elegant entry stoop with brick walls and ornamental iron detailing
- Brick paved sidewalk and leadwalk
- Recessed front entry
- Half round aluminum gutters and round downspouts in bronze finish
- Professionally landscaped community open spaces and courtyards
- Community swimming pool and clubhouse

INTERIOR APPOINTMENTS

- Four finished levels
- 3" wide hardwood floor planks in living room, dining room, kitchen, breakfast area, and powder room
- Custom crafted crown molding in foyer, living room, dining room, and owner's suite
- 2-piece chair rail in dining room
- Oversized base molding and window trim
- Oversized door trim with plinth blocks
- Gas fireplace with choice of marble or granite surround in living room
- Oak staircase at entry level
- 2-panel, semi-solid, smooth finish doors with 8' heights on main level
- 10' ceilings on main level
- Advanced home wiring system for distribution of multi-media, fax, modem, and high-speed Internet access
- 2-tone interior paint
- Upgraded recessed lighting
- Security system
- Designer satin nickel lever door hardware

CHEF'S KITCHEN

- Designer cabinetry in stained maple finish with 42" upper cabinets, crown molding, and plywood dovetail drawers
- Granite countertops and backsplash
- 3" wide hardwood floor planks
- Viking™ 6-burner stove with stainless steel vent hood above
- Built-in KitchenAid™ wall oven and microwave/convection oven
- Built-in 42" side-by-side KitchenAid™ refrigerator with water and ice dispenser
- Multi-cycle insulated KitchenAid™ dishwasher with stainless steel interior and hidden control panel
- Undermount stainless steel single bowl sink with pullout spray faucet
- Upgraded recessed lighting
- Pantry storage
- Push-button garbage disposal

LUXURIOUS BATHS

- Owner's bath includes:
 - 12" x 12" Ceramic tile laid diagonally
 - Soaking tub with jets and personal hand-shower
 - Double vanity with granite countertop and drop in sinks
 - Separate shower with frameless glass enclosure and ceramic tile base
- 6" x 6" ceramic tile in secondary baths
- Cultured marble vanity tops
- Elongated water closets
- Chrome Kohler™ faucets
- Kohler™ pedestal sink in powder room

QUALITY CONSTRUCTION & SAFETY FEATURES

- Engineered wall system
- Engineered floor system
- CPVC piping
- Insulated party wall system
- Fire sprinkler system
- Brick exterior
- 2-10 Home Buyer's Warranty™
- Pre-construction meeting
- Pre-drywall walkthrough
- Pre-settlement orientation

ENERGY EFFICIENCY

- Energy efficient two-zone heating and cooling with gas heat on main zone and heat pump on secondary zone
- House wrap and energy seal package
- 80-gallon electric water heater
- Insulation specifications include:
 - R38 insulation in roof
 - R13 insulation in exterior walls
- Insulated garage door
- Double-pane simulated divided light windows

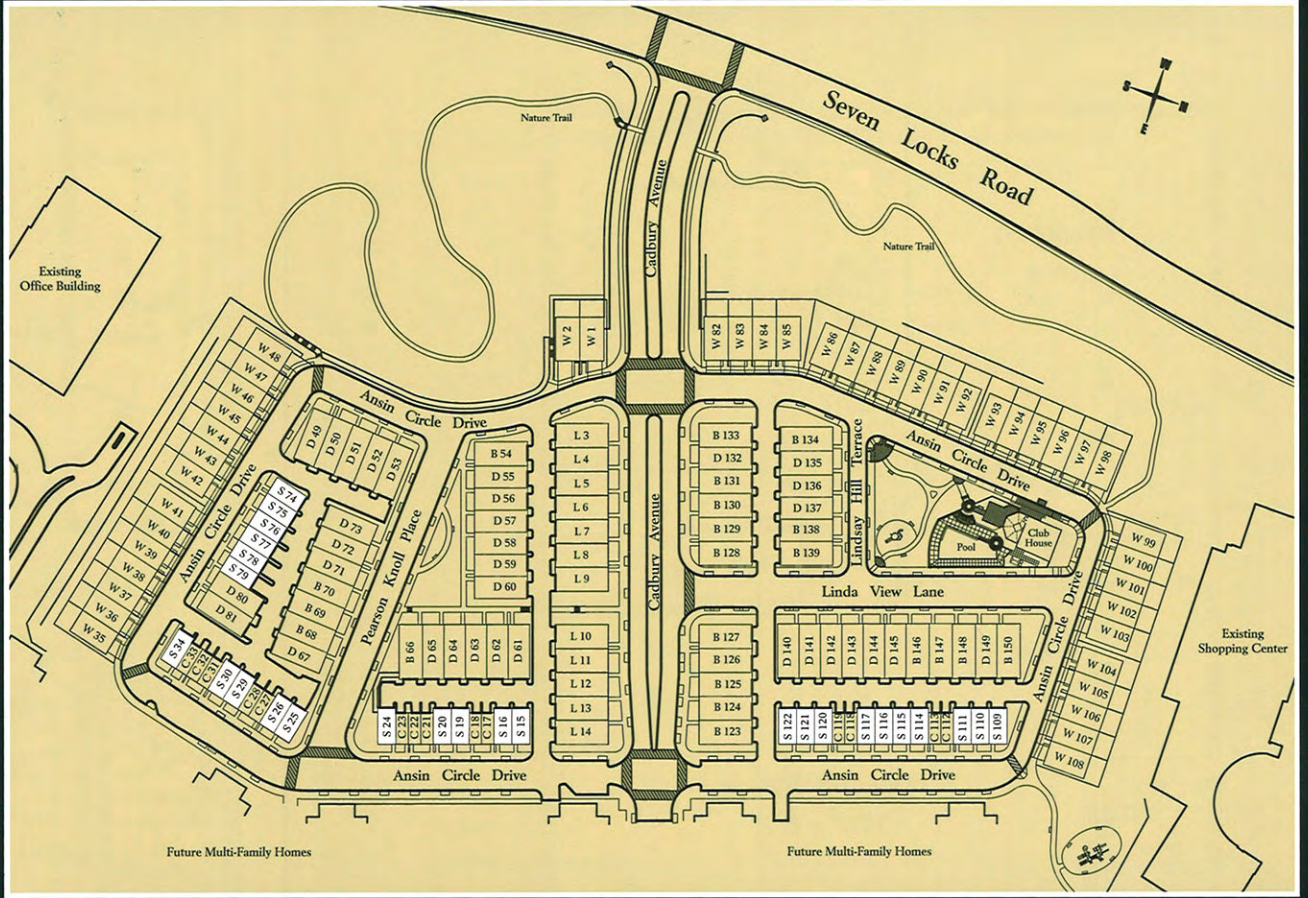

The Brownstones at
PARK POTOMAC

Potomac, Maryland

THE NEIGHBORHOODS OF



eya.com



Because of continuing changes in products, building codes and availability of materials, Builder reserves the right to incorporate new and improved design features at any time without notice or to use equivalent materials. All dimensions shown in this brochure are approximate and plans, specifications and standard features are subject to modifications and improvements at any time without notice. Room dimensions may vary between the brochure, model homes and the individually built homes. The brochure illustrations are artist's concepts and may vary in detail from plans and specifications.